

# CRYSTAL

## WALL LIGHT



### FEATURES

- High efficiency LED Wall Light 140 lm/W.
- IP65 protection against moisture and dust.
- Shielded LED source reduces glare.
- CCT: 3000K-4000K-5000K
- Removable hinged door for easy and quick installation.

### APPLICATION

Common applications: Perimeter lighting for warehouse, walkway, corridor & etc.



### PRODUCT DIMENSION

\*Typical Dimension (mm)

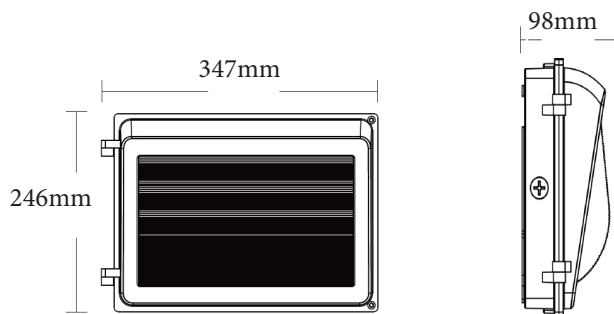

### PHOTOMETRIC DATA

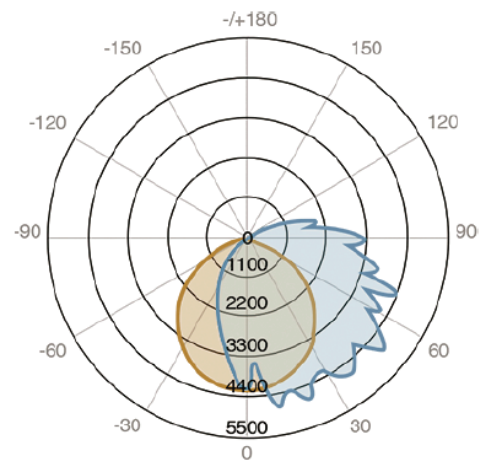

Model No.	Crystal SA30	Crystal SA40	Crystal SA60
Power Consumption(W)	30	40	60
Luminaire Flux ± 5% (lm)	4200	5600	8400
Input Voltage (Vac)	120-277		
Power Factor(PF)	≥ 0.90		
Efficiency (%)	≥ 0.87		
Net Weight/pc(kg)	2.3		

Note: The above specified lumen and system subject to changes without prior notice.  
 Also available colour temperature upon request: 3000K,4000K

**TECHNICAL SPECIFICATION**

**ELECTRICAL SYSTEM**

Input Voltage	Insulation Class	LED Driver
100-277Vac, 50/60Hz, PF > 0.9	Class 1	Constant current Driver

Light Source	LED Type	(CRI)	Life Time Residual Flux	Optical System
COB	COB	≥80	(L80), >40,000 hours	Internal Aluminium reflector/Tempered glass

**CERTIFICATION & COMPLIANCE TEST**

- : EN IEC 60598-2-1:2021
- : EN IEC 60598-1:2021+A11:2022
- : EN 62493:2015+A1:2022
- : EN IEC 62031:2020+A11:2021
- : EN IEC 55015:2019+A11:2020
- : EN IEC 61000-3-2:2019+A1:2021
- : EN 1000-3-3:2013+A1:2019+A2:2021
- : EN 61547:2009

**FIXTURE/HOUSING**

- Housing: Die-Cast Aluminium
- Heat tempered glass diffuser

**OPTIONAL ACCESSORIES**

- Photocell
- Micro wave sensor
- Sensor remote control